



**Modular Cooking Range Line
Electric Freestanding Rethermalizer,
1 Well - 16gal (60 litres)**

ITEM # _____
 MODEL # _____
 NAME # _____
 SIS # _____
 AIA # _____



Modular Cooking Range Line
 Electric Freestanding Rethermalizer, 1 Well - 16gal (60 litres)



391351 (E9PCEDRMC3) Electric Freestanding Rethermalizer, 1 Well - 16gal (60 litres)

Short Form Specification

Item No. _____

Electric freestanding re-thermalizer unit for soups. 60 liters water well capacity, able to fit and re-thermalize 10 soup bags simultaneously in 20 minutes, from 38°F to 176°F, thus optimizing energy and water consumption. Unit designed to operate using only electric power, water inlet and water discharge, no other connections required. Easy to use electronic control panel with LED display allows to choose between two program cycles - default re-therm program and "searing" program. Infrared heating system located in the external base of the well. Safety thermostat prevents the machine from working without water. Well equipped with 2 dedicated AISI 304 stainless steel racks, fitting 5 bags each (10 bags total).

Main Features

- Easy to use electronic control panel with LED display showing water temperature and re-therm cycle countdown. An acoustic alarm warns the operator when the cycle is completed.
- Two program cycles available:
 - Default re-therm program: the cycle allows the rethermalization of minimum 2 and up to a maximum of 10 bags of soup from 38°F to 176°F (3°C to 80°C) in 40 minutes (at an ambient temperature of 77°F (25°C). Times may vary depending on soup and bag type as well as bag temperature).
 - "Searing" program: allows the operator to extend the re-therm cycle for additional 10 minutes, if a higher temperature is required.
- Well equipped with a dedicated temperature sensor to control the water temperature and 4 additional sensors to manage the water level.
- Safety thermostat automatically switches off the appliance in case of overheating.
- Automatic water level filling and re-filling.
- Well equipped with 2 dedicated AISI 304 stainless steel racks, able to fit 5 bags each (10 bags totally). The racks have a flexible wall to maintain the correct bag position during the cycle, thus guaranteeing maximum performances.

Construction

- Water basin in 316-L type Stainless steel to avoid corrosion.
- One piece pressed 1/25" (1.5mm) worktop in stainless steel with smooth, rounded corners.
- Exterior panels in stainless steel with Scotch Brite finish. Back, bottom and front made in stainless steel.
- Stainless Steel removable support located inside the well to support the soup bags.
- High efficiency infrared heating system positioned under the external base of the well to ensure elevated performances.
- Electric control with display indicating pre-heating phase (with time hidden when starting from cold water), water temperature, residual time for "retherm" cycle.
- Safety thermostat automatically switches off the appliance in case of overheating.
- Rear hinged swiveling cover and handle with spring torsion mechanism acting on cams to allow the cover to remain open during operations.
- Water drain positioned on the bottom of the appliance.
- Mounted on 6in-8in (150-200mm) high feet.
- Equipped with 6.5' (2m) cable without plug.
- Appliance is IPX4 water resistance certified.
- Water inlet electrovalve.
- Microswitch preventing the use of the appliance if the drain valve is not closed.

APPROVAL: _____

Front

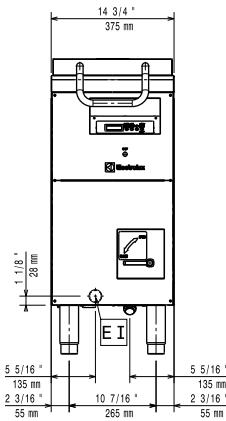

Side

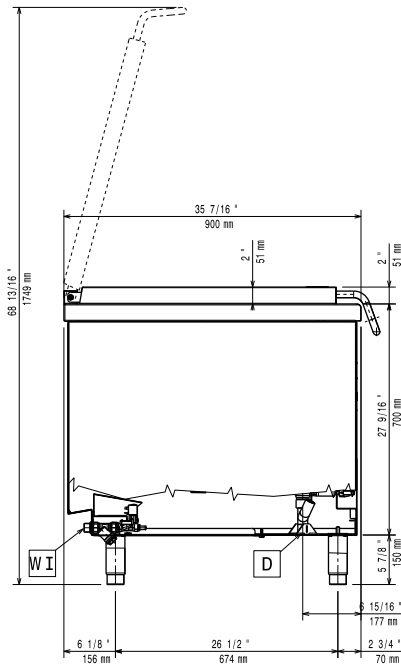

D = Drain
EI = Electrical connection
EQ = Equipotential screw
WI = Water inlet

Top

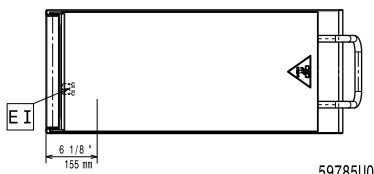

Electric

Amps

391351 (E9PCEDRMC3) 25 A

Supply voltage: 208 V/3 ph/60 Hz

Electrical power, max: 9 kW

Total Watts: 9 kW

Water:

Incoming Cold/hot Water line size: 3/4"

Drain line size: 3/4"

Key Information:

Available spare parts:

- Bag separator (OCA834)
- Soup holder (OCA835)
- Filter (OCA956)
- Soup Holder, complete assy (OCA959)

Number of wells: 1

Usable well dimensions (width): 11 13/16" (300 mm)

Usable well dimensions (depth): 26 3/4" (680 mm)

Usable well dimensions (height): 15 3/8" (390 mm)

Well capacity: gal (0 liters) MIN; 15.85 gal (60 liters) MAX

Thermostat Range: 185 °F MIN; 203 °F MAX

External dimensions, Width: 14 3/4" (375 mm)

External dimensions, Depth: 35 13/16" (910 mm)

External dimensions, Height: 33 7/16" (850 mm)

Net weight: 121 lbs (55 kg)

Shipping width: 40 15/16" (1040 mm)

Shipping depth: 18 7/8" (480 mm)

Shipping height: 44 1/16" (1120 mm)

Shipping weight: 181 lbs (82 kg)

Shipping volume: 19.74 ft³ (0.56 m³)

Configuration: Free Standing

ETL C&US;ETL SANITATION

Approvals

Certification group: ROHU